

CAVIUS



RELAY INTERFACE

PLEASE READ THIS USER GUIDE CAREFULLY

CONTENTS

1. PRODUCT FEATURES AND SPECIFICATIONS	3
2. OPERATIONAL	5
3. HOW TO SET UP RELAY AND CONNECT CAVIUS WIRELESS FAMILY ALARMS	7
4. INSTALLATION INSTRUCTIONS	8
5. TEST FUNCTION	13
6. ADD EXTRA DEVICE	14

1. PRODUCT FEATURES AND SPECIFICATIONS

Model: 9005 CAVRI. Mains powered relay interface with RF interconnect.

The 9005 CAVRI Relay Interface is primarily intended to enable a connection between an external system or devices and the CAVIUS Wireless Family.

- Electrical Rating: 230 VAC, 50 Hz, 1.8 W
- Battery Life: 1-year life in battery mode without mains power, and up to 10-years normal life with mains power.
- Replacement Battery: Duracell CR2 or Procell CR2
- Relay Contacts rating: 250 VAC @ 5 Amps or 30 VDC @ 5 Amps
- Trigger I/P voltage: 3 to 30 V DC
- Low Battery : A short beep will sound out every 48 seconds for 30 days.
- Red LED for RF Learn Mode / Alarm / Fault
- Green LED for mains power on.
- Test button is used to setup wireless interconnect, and test.
- Wireless Radio Frequency: 926.365 MHz, max 20 mW
- Wireless Interconnect: up to 32 units
- Operating Temperature Range: 0°C to 40°C
- Humidity Range: 0% to 90% RH, non-condensing
- Latched or Pulsed relay output (user selectable), see Section 2, Figure 2.

Features

FIGURE 1

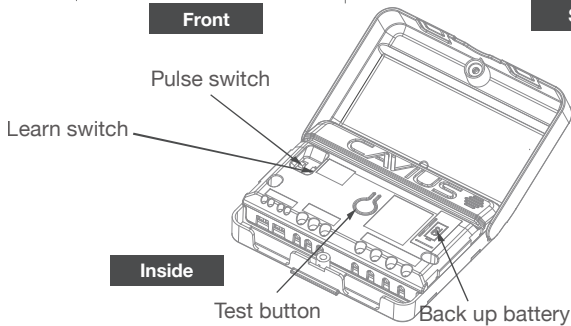
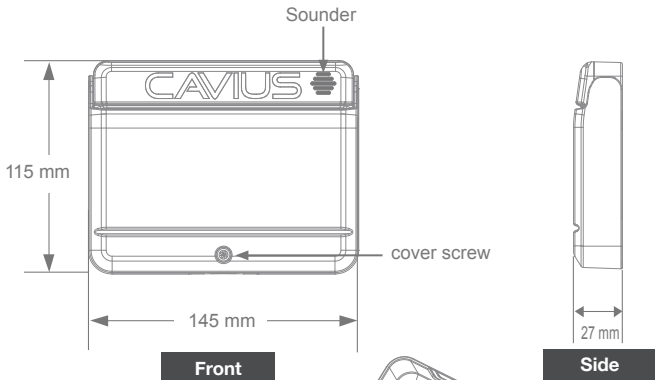

2. OPERATIONAL

The 9005 CAVRI relay can be RF interlinked with other CAVIUS Wireless Family alarms. The maximum number of alarms that can be interlinked within a house group is 32 units. The wireless distance between interlinked alarms depends on the house layout and they should always be tested after installation. It is not advisable to install alarms with a separation of more than 10m. **Please note:** These must be alarms from the CAVIUS Wireless Alarm Family.

The 9005 CAVRI Relay provides a set of Normally Closed (NC) and Normally Open (NO) change over contacts. This enables CAVIUS smoke and heat alarms to trigger auxiliary devices such as Telecare Systems, strobe lights, sounders, fire alarm panels, activate emergency lights, shut down air conditioners or release magnetic door holders. Third party devices such as sprinkler flow switches or fire panels can also be connected to the trigger input to cause the CAVIUS alarms to sound when activated.

This relay has 2 selectable modes of operation.
Select the mode of operation using PULSE switch (See Figure 2).

Pulse OFF:

Relay activates continuously when the smoke and /or heat alarm is in the alarm condition

Pulse ON:

Relay activates for approximately 5 seconds when the smoke and /or heat alarm is in the alarm condition.

ON



OFF

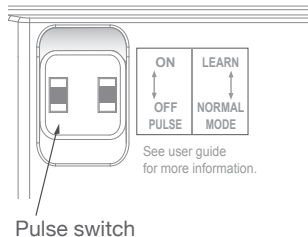

LED indication

There are two LED that indicate the following.

Green

- **ON** – AC Power/mains supply is present
- **OFF** – AC Power/mains supply is not present

Red

The Red LED indicates the following conditions.

- **Learn mode condition:**
Red LED on.
- **Alarm:**
The Red LED will not illuminate if the relay is activated by RF alarms.
- **Trigger input detected:**
The Red LED will flash every 0.5 seconds if a trigger input from an external device is detected. Note: The Relay Interface red LED will not illuminate if the relay is activated by CAVIUS smoke or heat alarms.
- **Battery fault:**
In normal operation the red LED will flash every 48 seconds. If the battery is in a low voltage condition or faulty, the red LED will flash every 48 seconds and the sounder will chirp in time.

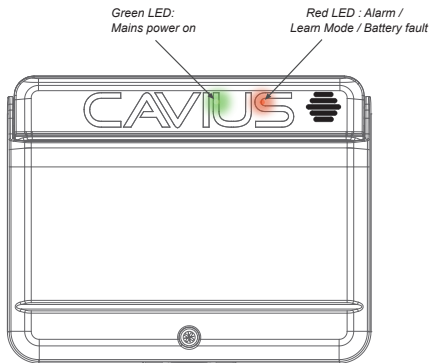

FIGURE 3

3. HOW TO SET UP RELAY AND CONNECT CAVIUS WIRELESS FAMILY ALARMS

The Relay & all alarms that need to be connected in the house should be put into “Learn Mode” by sliding the switch on the inside of the relay (Figure 4) and back of the alarms to the “LEARN” position.

The red LED will illuminate to indicate that ‘Learn Mode’ has been selected.

Press and hold the test button on one device only, until it beeps and the LED flashes. This device will become the master and will start sending out a specific house code to the other RF device. See Figure 5.

As the other device receives the specific house code, they will also flash the LED light.

When the red LED light flashes on RF Relay Interface and all CAVIUS Wireless Family alarms, they are connected and **MUST BE SWITCHED OUT OF ‘LEARN MODE’** and installed. See Figure 4.

Leaving the RF relay in learn mode for an extended time will reduce the battery life.

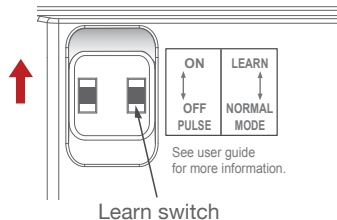

FIGURE 4

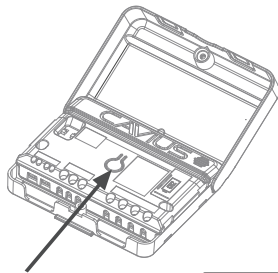



FIGURE 5

4. INSTALLATION INSTRUCTIONS

The 9005 CAVRI RF relay must be on a circuit breaker and be installed in a suitable location according to local building regulations and codes of practice.

 **WARNING:** Disconnect mains power before commencing work.

A. Remove cover (cover screw) to allow access to wire connections. See Figure 6.

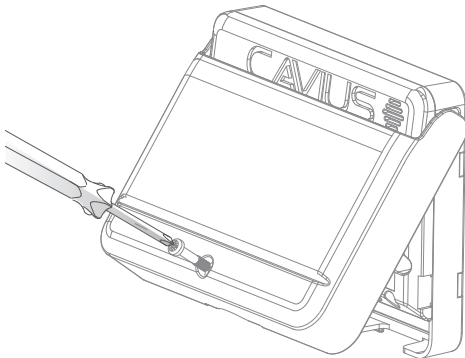

FIGURE 6

B. Mount in required location.

Mark and drill two holes for wall or ceiling anchors.

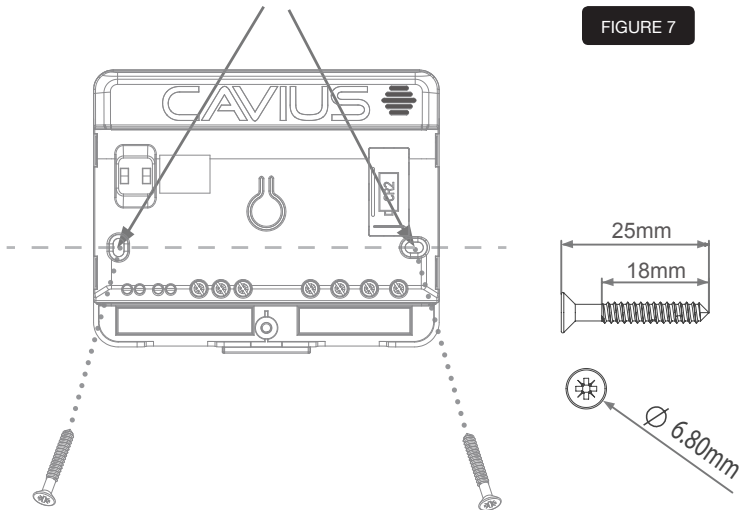



FIGURE 7

C. After the cables are connected, press the Test button. Please re-install the module cover.

Wiring Instructions:

 **WARNING:** Alarm and relay module wiring installation must comply with the current edition of AS3000, Wiring Regulations and all appropriate prevailing local/national building regulations and codes of practice.

Product must be installed by a qualified electrician. Failure to install this product correctly may expose the user to electric shock or fire risk hazards. This relay module is not rated as waterproof and must not be exposed to dripping or splashing water. The relay module must be installed correctly to function. The electrical circuit used to power the relay module must be 240 volt AC 50Hz.

 **WARNING:** This product cannot be operated from power derived from a square wave, modified square wave or modified sine wave inverter. These type of inverters are sometimes used to supply power to the structure in 'off grid' installations, such as solar or wind derived power sources. These power sources produce high peak voltages that can damage the device.

 **IMPORTANT:** It is recommended that the module and alarms are connected to a dedicated circuit that is separately electrically protected. This helps minimise interference (EMI) on alarm interconnect line from CFL's, dimmers, LV transformers etc.

Make sure that AC power is turned off before starting the installation.

This 9005 CAVRI Relay Interface will not detect smoke or heat. This wireless module can only interconnect with compatible smoke alarms or relay. Interconnection with other brands may cause damage, result in electric shock, fire risk and void warranty.

The earth terminal connection provided is for termination purposes only and is NOT electrically connected within the sealed alarm / base units.

Terminals on the module are marked as shown in figure 9:

MARKINGS

Output Relay

NO	Normally Open
C	Common
NC	Normally Closed

Input Trigger

SW	Switch Return
3V	Switch Feed

Voltage Trigger

0V	0V
+V	+3 V to +30 V

AC Mains

L	Live
N	Neutral
	Earth

 **WARNING:** Connecting the switch terminals to any other supply conductor may result in damage to the alarm, failure to operate or shock hazard and void the warranty of the alarm.

RELAY OPERATION

The RF relay may take a few seconds to operate when the smoke alarm or heat alarm is activated or reset. This is normal operation.

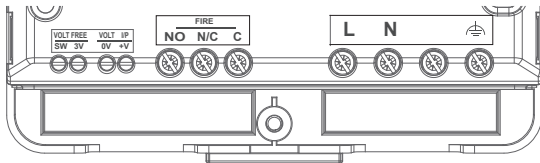

Tighten terminal screws 0.3 to 0.5 N.m.

FIGURE 8

The wiring connecting the module with the external device is not supervised. Be sure to test the operation of all the devices controlling the module or controlled by the module. Devices controlled by the module can be tested by pushing the Test button on the relay and verifying that the controlled device responds in the desired manner.

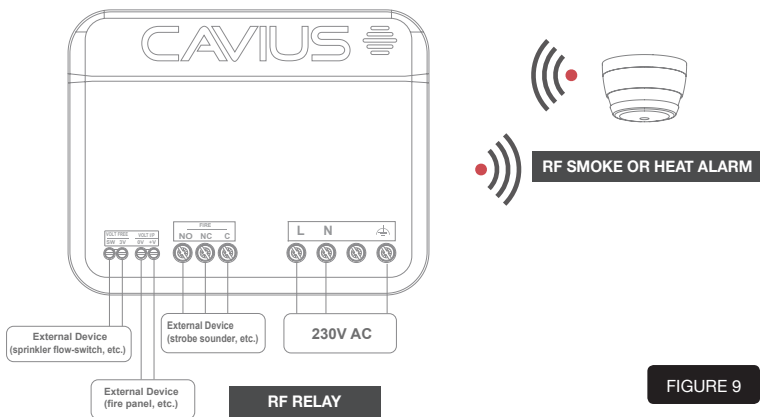

FIGURE 9

By installing the RF relay in this manner it will allow you to operate devices such as telecare systems, sounders, strobes, or any devices which do not exceed 250VAC @ 5 Amps.

5. TEST FUNCTION

After installation, test the RF relay and alarms to ensure they are operating correctly and are within range of each other.

Press the test button on the relay for two sets of sweeps and until the sounder stops. Release the button and this will send out the test signal to all connected alarms.

When the test signal is sent out, the relay will respond in two ways:

- a. A single beep every 8 seconds indicates that the relay is connected and functioning.
- b. Three short beeps every 8 seconds indicates a relay fault.

The test function will time out after 2 minutes, but can be stopped earlier by a short press of the test button on the relay.

After system tests are complete, close the cover and tighten the securing screw to limit access.

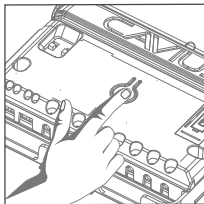

ENVIRONMENTAL PROTECTION

Waste electrical products should not be disposed of with household waste.

Please recycle where facilities exist. Check with your local authority or retailer for recycling advice



6. ADD EXTRA DEVICES

All CAVIUS interconnected alarms within the  can be added to the system as they run on same frequency and use the same data protocol.

Place all Wireless Family alarms & Relay to be interconnected into 'Learn Mode' and repeat section 3. Always test connection to all devices by Test button (section 5).

Developed & Manufactured by:

Carrier Fire & Security Danmark A/S,
Ellekær 9A, 2. Th, DK-2730, Denmark

cavius.com - info@cavius.com
Manufactured in P.R.C.

Distributor information:

for *New Zealand* - CAVIUS Nano Ltd.

58a Poplar Lane, Papamoa 3187, NZ. **www.cavius.co.nz**

for *Australia* - CAVIUS Australia PTY LTD

GPO Box 303, Brisbane, QLD 4001, Australia. **www.cavius.com.au**

WIRELESS 
ALARM FAMILY



CAVIUS WIRELESS FAMILY
MAINS POWERED
PHOTOELECTRIC SMOKE ALARM



CAVIUS WIRELESS FAMILY
10 YEAR PHOTOELECTRIC
SMOKE ALARM

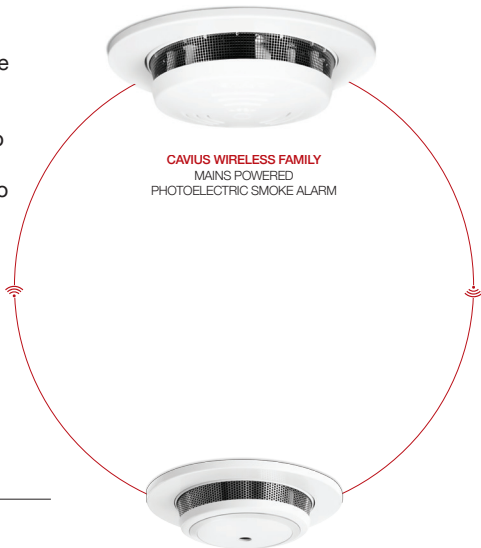

Warranty:

CAVIUS provides a 10-year warranty against defect in faulty material and workmanship from the date of purchase, on all devices.

The warranty applies to reasonable and normal conditions of use only. It does not include damage as a result of misuse, incorrect installation, accidental damage, neglect, unauthorised deconstruction or dismantling and any airborne or other contamination however this may have occurred.

If this product has an acknowledged defect it must be returned to the national CAVIUS Distributor at the purchasers cost with the proof of purchase.

If the product has become defective within the 10-year warranty, Carrier Fire & Security Danmark A/S, Denmark will repair or replace the unit without charge and send back to the purchaser, via the national Distributor at the Distributors cost.

The guarantee excludes labour costs, freight costs, service costs and any incidental and consequential damages. Do not attempt to repair or service this product as this will invalidate the warranty.

Under some unusual circumstances the presence of high levels of radio spectrum pollution may result in the batteries within the CAVIUS device not lasting as indicated in the product sheet. Radio spectrum pollution comprises transmissions inside the band allocated for alarm devices such as the CAVIUS devices. Such transmissions may activate the receiver inside the devices for a longer time than is normal in standby.

This is not a specific problem for CAVIUS devices but for all similar radio linked technology powered by batteries. The limited warranty will not cover the battery life period indicated in the product sheet in these situations.

This warranty is in lieu of any other warranty either expressed or implied.

You can register your CAVIUS devices on our website.



CAVIUS

THE WORLD'S SMALLEST SMOKE ALARMS

REGISTER YOUR CAVIUS PRODUCT WITH US
& GO INTO THE DRAW TO WIN

FIND DETAILS AT

[CAVIUS.CO.NZ/WARRANTY](https://cavius.co.nz/warranty)